

DOUBLE PERISTALTIC SYSTEM

MP DUAL PH/REDOX

Data
Sheet

DESCRIPTION

- ✓ Double system with built in PH /REDOX and Temperature C° controller
- ✓ Flow rate showed in percentage
- ✓ 3 different functioning mode: **constant, ON / OFF, proportional**
- ✓ Menu available in 4 languages: **ITALIAN, ENGLISH, FRANCE, SPANISH**
- ✓ Password protected
- ✓ Startup delay
- ✓ Time overdose alarm (TAL System)
- ✓ Alarm relay (free contact)
- ✓ Default parameter restore option
- ✓ PH Stability mode (programmable)
- ✓ STAND BY mode
- ✓ Over / under range signal
- ✓ Backlit LCD Display
- ✓ Box in PP reinforced
- ✓ IP 65
- ✓ Power Supply 230vac 50-60 Hz



OPTIONAL

- ✓ Level probe input
- ✓ Flow sensor input
- ✓ ON / OFF switch

SPECIFICATIONS

Standard VERSION

Case	PP	-----
Rollers	DELRIN	-----
Tube	Santoprene	-----
Power consumption	8 Watt	-----
Ring Nuts	PP M10	-----
Fittings	PP 4 x 6	-----
Probe connection	BNC	-----
Foot filter valve	Lip Valve	-----
Suction tube	PVC 4 x 6	-----
Delivery tube	PE 4 x 6	-----

Specifications subject to change without further notice

Via Maestri del Lavoro,5 - 02100 Vazia (RI) - ITALY Tel.:+ 39(0)746-229064; Fax:+ 39(0)746-221224
e-mail: info@microdos.it ; Web site: www.microdos.it

DOUBLE PERISTALTIC SYSTEM MP DUAL PH E REDOX

Data Sheet

SPECIFICATIONS

Standard	Max l/h	Pressure		Max cc / min	Santoprene tube	Case	Watt	RPM	Weight	
		Bar	PSI						kg.	Lbs
PH Pump	1,5	01	14,7	25	5,8 x 9,3	PP	21	10	3,6	6,7
	03	01	14,7	50				20		
REDOX Pump	06	01	14,7	100				40		

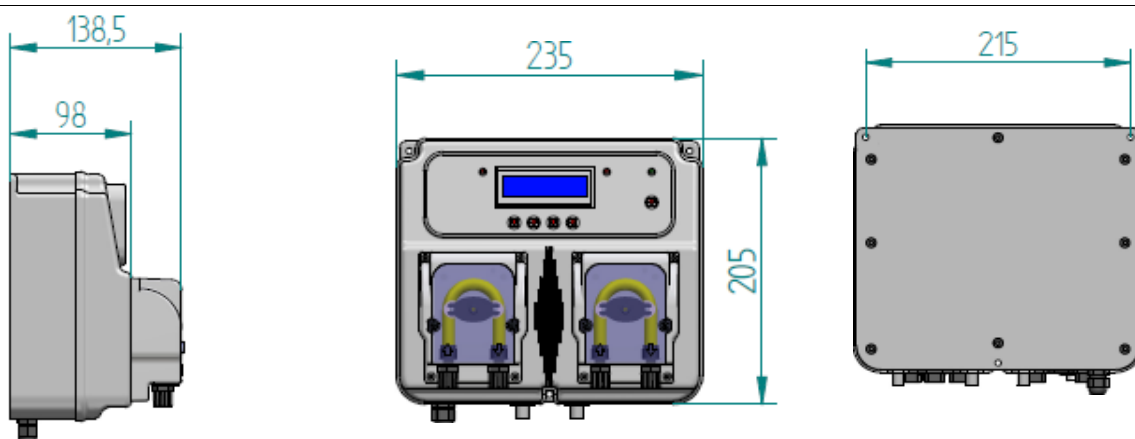

Dimensions

ACCESSORIES KIT



Specifications subject to change without further notice

Via Maestri del Lavoro,5 - 02100 Vazia (RI) - ITALY Tel.: + 39(0)746-229064; Fax: + 39(0)746-221224
e-mail: info@microdos.it ; Web site: www.microdos.it